



MF108 INTERLOCKING FLAT

THE LEADER IN THE CLAY ROOF TILE INDUSTRY IN THE U.S.A.





C16 Matte Black - Rancho Santa Fe, CA

MCA's MF108 Flat Interlocking Tile accentuates any architectural theme and makes an impressive statement on any style building or home. It will keep its distinctive appearance while withstanding constant exposure to weather conditions. MF108 is used extensively on commercial, institutional buildings, military buildings and resort projects, as well as custom homes. There are 108 pieces per square, which makes it labor efficient and provides cost savings.

This beautiful clay tile is available in Natural Red and various glazed colors. Custom colors are also available.

Using MF108 Flat tile truly defines the results of art, craftsmanship and the opportunity to experience lasting beauty.

A 50-Year Limited Warranty is available on all MCA tiles.

For more information, please contact MCA sales office at 1-800-736-6221 or sales@mca-tile.com.

CC/CODES, CERTIFICATIONS

- IAPMO UES ER-356*
- TDI Approval RC-21
- Florida Building Code - FL22539.6
- Miami-Dade County NOA No. 14-1020.01
- Class A, E108 (UL790)
- ASTM C1167, Grade 1
- Made in Japan



*IAPMO UES Evaluation Report covers City of Los Angeles and is in lieu of ICC-ES.

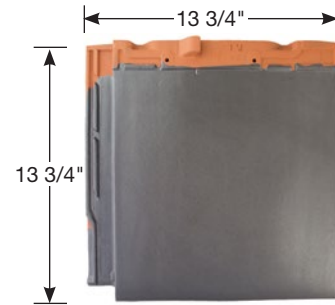

TILE SPECIFICATIONS:

Actual Size:	13 3/4" x 13 3/4"
Exposed Size:	11 1/8" x 12"
Weight per Square:	879 lbs.
Weight per Piece:	8.14 lbs.
No. of Pieces per Square:	108 pcs

METRIC TILE SPECIFICATIONS:

Actual Size:	345mm x 345mm
Exposed Size:	282mm x 305mm
Weight per M2:	42.8 kg
Weight per piece:	3.69 kg
No. of Pieces per M2	11.6 pcs

Metric conversion of lumber is actual dimensions of lumber; use lumber of the closest dimensions available.



Natural Red
F40*



Matte Green
C22



Matte Black
C16



Metallic Silver
C23



Antique Brown
C28



Adobe Brown
C42



Silver Gray
C44



Sky Blue
C49



White
C25

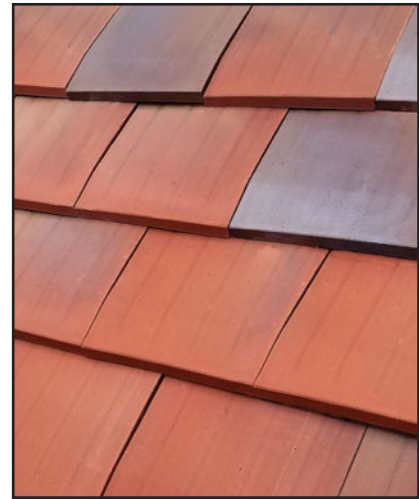

Kiln Flash
C50*

NOTE: Some tiles may have slight variations in color due to the inherent nature of clay tile and the limitations of the lithographic printing process
*F40 Natural Red and C50 Kiln Flash are not standard items in MF108 Flat. Must be requested in advance. Extended lead times may apply.

MF108 Interlocking Flat Products

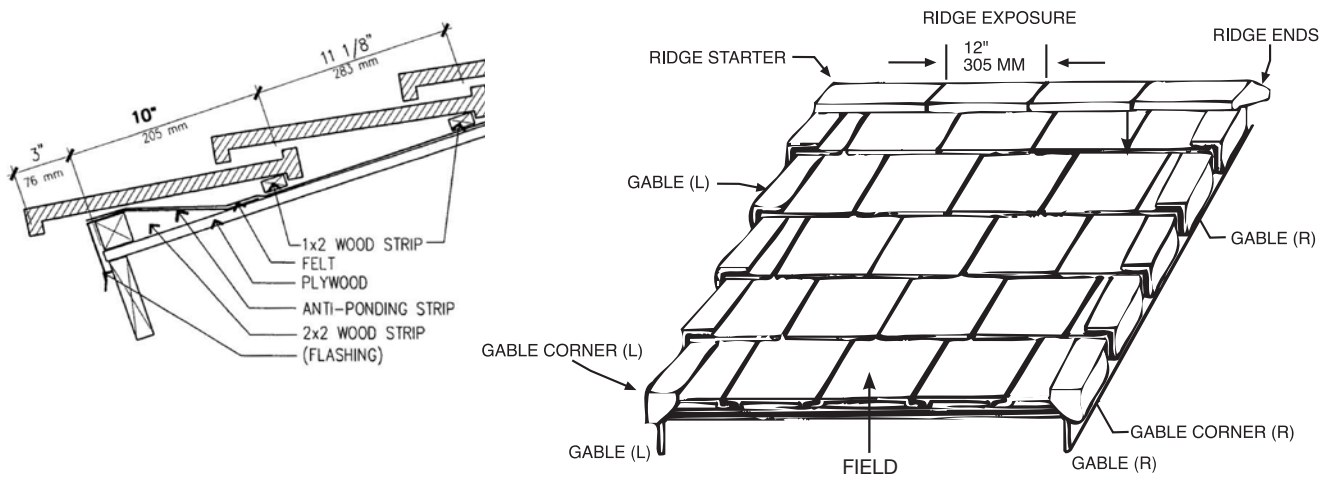

(Edit as required. Delete non-applicable statements.)

1. GENERAL

(use the standard Part1 of your office)

2. PRODUCTS

2.1. ROOFING TILE:

- A. Where indicated on the Drawings, provide MF108 Flat Interlocking Style roofing tile manufactured by M.C.A. Superior Clay Roof Tile located at 1985 Sampson Ave., Corona, CA 92879, phone (800) 736-6221, fax (951) 736-6052, in color number "C-" and with the appropriate number of the following matching accessory tiles to complete the installation:

1. Field Tiles - MF10801;
2. Gable Tiles - MF10803/MF10804 (right and left as required);
3. Gable Corners - MF10805/MF10806 (right and left as required);
4. Ridge Hip - MF10807;
5. 3 - Forked Ridge - MF10808;
6. Ridge End - MF10809;
7. Ridge Down End - MF10810;
8. Ridge Starter - MF10811;

2.2. Other materials:

A. Membrane:

1. Under all MF108 Flat Interlocking Style tile roofing except where heavier membrane is required by governmental agencies having jurisdiction, provide not less than two layers of 30 membrane complying with ASTM D226, Type II, or one layer of Type 40 membrane complying with ASTM D2626, Type I, or upgraded membrane.
2. Install in strict accordance with pertinent requirements of governmental and/or other agencies having jurisdiction.

B. Fasteners:

1. For tiles and cleats, use copper or other corrosion-resistant nails not less than No. 11 gage, no less than 5/16" (7.9 mm) head complying with ASTM F1667.
2. At plywood decks, use ring shank nails in length sufficient for slight penetration through underside of the deck.
3. At board plank decks, use smooth shank nails at least 1-1/2" (38mm) long but not penetrating the underside of the deck.
4. At Gypsum plank and nailable concrete decks:
 - a. Use stainless steel or silicon bronze screw shank nails of length sufficient to penetrate 1/2 to 3/4 their length into the deck.
 - b. Do not penetrate underside of the deck.
 - c. If deck material is excessively hard, use smooth shank nails.
5. Provide two fasteners per tile at snow areas.
6. In areas designated by the building official as being subject to winds that exceed 80 mph, or where roof height exceeds 40 feet (12 m) above grade, attach all tiles in strict accordance with Chapter 15 of UBC (or IBC Table 15-D=1, footnote 2), or as required by governmental agencies having jurisdiction.
 - a. Nail the heads of all ties;
 - b. Fasten the noses of all eave course tiles with approved clips;
 - c. Nail rake tiles with two nails;
 - d. Set noses of all ridge, hip, and rake tiles in a bead of mastic approved by the Architect.

7. On slopes over 24:12, securely fasten the noses of all tiles.

8. Provide "Wind Locks" where directed by the Architect.

C. Wood Strips and nailers:

1. Eave Strip: Where MF108 Flat Interlocking Style roofing tile will be installed, provide 2" x 2" (50mm x 50mm) Foundation Grade Redwood strip full length at all eaves to raise the first course of roofing tiles.
2. Nailers: Thereafter, use 1" x 2" (25mm x 50mm) wood battens installed horizontally at 9-1/8"

(228mm) centers thereafter.

3. Where indicated on Drawings or otherwise required for proper nailing, provide 2" x 2" (50mm x 50mm) and 2" x 4" (50mm x 102mm) Foundation Grade Redwood nailers at ridge and hip.

D. Flashing:

1. Flash at roof valleys in strict accordance with Chapter 15 of UBC, or IBC, or required by local governmental agencies having jurisdiction.
 - a. For valley flashing use not lighter than 26 gage (0.55 mm thick) G90 corrosion-resistant metal, extending at least 11" (279 mm) away from the centerline of the valley each way;
 - b. Provide splash diverter rib not less than 1" (25mm) high at the flow line, formed as part of the flashing;
 - c. Provide flashing overlap of not less than 4" (102 mm).
 2. At sides of dormers, chimneys, and other walls, extend flashing at least 6" (152 mm) up the vertical surface.
 - a. Thoroughly counter flash;
 - b. Extend flashing under tile at least 4" (102 mm), and turn the side edge up 1 1/2" (38 mm).
 3. At lower side of dormers, chimneys, and other walls, extend flashing at least 3" (76 mm) up the wall and 4" (102 mm) over the tile, and then thoroughly counterflash.
 4. At wood saddles and returns, line with 16 oz (45 g) copper extending up sloping roofs not less than 12" (305 mm), and more where necessary, and up vertical walls not less than 6" (152 mm), thoroughly counterflashed.
 5. Make all counterflashing plugged, pointed and secure.
 6. Extend gutter metal up the roof to a point higher than the outer edge of the gutter.
- E. Mortar, plastic cement, and sealant:
1. Cut valley tiles and remove loose pieces.
 2. To prevent lift up of tiles at hip, ridge, and gable, provide plastic cement at headlap portion of those tiles.
 3. For gable rakes, hip rolls, ridges, stringers, and other conditions, provide a non-running, heavy body, plastic cement composed of asphalt and other mineral ingredients complying with ASTM D4586 and Fed Spec SSC-153 Type I.
 4. When using sealant in lieu of the plastic cement, provide a silicone sealant complying with ASTM D1002 or ASTM E42.

2.3 FOR POURED CONCRETE ROOF DECKS:

A. If roof is poured concrete:

1. As part of the work of another Section of these Specifications, provide embedded in the concrete roof deck 1" x 2" (25mm x 50mm) beveled wood nailer strips extending from eave to ridge, spaced at 20" (500mm) centers.
2. Finish the concrete roof deck smooth and flush with the tops of the wood nailer strips.
3. As part of the work of this Section, and in lieu of the membrane described in Paragraph 2.2-A above, provide a membrane over the concrete deck consisting of asphalt-saturated felt weighing not less than 50 lbs per 100 sq ft (23kg per 9.3 m²), fastening with wood lath nailed into the embedded wood nailer strips.
4. Across the wood lath, apply the appropriate wood strips and battens as described in Paragraph 2.2.B.

2.4. OTHER MATERIALS

1. Provide other materials, not specifically described but required for a complete and proper installation, as selected by the Contractor subject to the approval of the Architect.

3. EXECUTION

3.1 SURFACE CONDITIONS:

- A. Examine the areas and conditions under which work of this Section will be performed. Correct conditions

detrimental to timely and proper completion of the work. Do not proceed until unsatisfactory conditions have been corrected.

3.2 INSTALLATION:

A. Membrane:

1. Verify that deck surfaces are clean and dry prior to installation of membrane.
2. Remove all foreign particles from substrate to assure proper seating and prevent water damage.
3. Install the specified membrane in strict accordance with pertinent requirements of governmental agencies having jurisdiction.

- B. On vertical applications, and on extremely steep pitches where wind currents may cause lift, set the butt of each tile in a bead of the specified plastic cement or sealant, or provide stainless steel "Wind Locks" at intervals. Use plastic cement and sealant carefully, and avoid smearing the exposed tile surface.

C. Chalk lines:

1. Chalk horizontal and vertical guide lines on the membrane to assure water tightness and proper appearance.
2. Space the chalk lines by measuring the delivered tiles for average length and width exposures.
3. Do not exceed and exposure length 1/4" (6 mm) beyond the average.

3.3 INSTALLING MF108 FLAT INTERLOCKING STYLE ROOFING TILES:

1. Wood strips:

- a. Install the specified eave strip full length of all eaves.
- b. Install the specified batten strips horizontally at 9-1/8" (228mm) centers on the first course and 11-1/8" (278mm) vertical exposure for all rows thereafter.

2. Install the tile in rows from right to left, beginning at lower right corner of the roof.

- a. Start at the lower right corner with field tile, this has a 12" width exposure.
- b. Install each tile successively, fastening each tile with a minimum of one of the specified fasteners.
- c. The second course is started at the lower right corner. Tiles should be laid staggered.
- d. Install Ridge, hip, in accordance with pertinent requirements of the governmental agencies having jurisdiction.

- (1) Provide cement mortar Type M complying with ASTM C270 at all ridges and hips to completely seal the area under ridge and hip tiles;

- (2) Install a thin coat of rich cement mortar (one part Type I portland cement complying with ASTM C150 to three parts sand complying with ASTM C144) along exposed edges of all ridge and hip tiles;
- (3) Completely and neatly fill and point up all voids.

3. To avoid color patterning, checker boarding, spotting, and stair stepping:

- a. After the installation of each 80 roofing tiles, make a visual inspection from the ground level and at a distance from the building of about 40 feet (12 m);
- b. Verify that color range is smooth with no abrupt changes.
- c. Make necessary corrections before proceeding with further installation.

3.4 CLEANING UP:

- A. Upon completion of the work of this Section, and as a condition of its acceptance, completely remove from the job site all tools, equipment, debris, and surplus materials pertaining to this portion of the work.

Metric conversion of lumber is actual dimensions of lumber; use lumber of the closest dimensions available.

OM/OPERATION, MAINTENANCE

Over 100 years of product knowledge has enabled us to create a roof tile that is highly resistant to chipping, wearing and fading. We stand behind our product 100%. To install M.C.A. Tile, use adequate numbers of skilled workmen who are thoroughly trained and experienced in the necessary crafts and who are completely familiar with the specified requirements and

the methods needed for proper performance of the work. M.C.A. Clay Roofing Tile may have color variations due to the inherent natural characteristics of the material used. To avoid color patterning, checkerboarding, spotting and stairstepping, the installer should periodically (after installing 80 pieces of roof tile) check the roof color from the ground level at approximately 40 feet (12m) from the building for a color "range." By following this

procedure, patterning or spotting should be avoided by blending the tiles over the entire deck. If this procedure is not followed, M.C.A. can not be held liable or responsible in any way once the tiles have been installed. All claims should be made in writing before installation of the tiles. No claims will be recognized after the tiles have been installed. Once M.C.A. Clay Roof Tiles are installed, no maintenance is required.



MCA[®]
Clay Roof Tile

MARUHACHI CERAMICS OF AMERICA, INC.
1985 SAMPSON AVENUE, CORONA, CA 92879, U.S.A
(800) 736-6221 • FAX (951) 736-6052
EMAIL: sales@mca-tile.com • www.mca-tile.com

Find MCA on
ARCAT

