

和形

Oriental-Japanese Style



MCA[®]
Clay Roof Tile

THE LEADER IN THE CLAY ROOF TILE INDUSTRY IN THE U.S.





Japanese Black C-09 (Ibushi) — Long Beach, CA

Oriental-Japanese Style

M.C.A.'s Oriental-Japanese tile is a unique, interlocking, high quality tile made in the Japanese tradition. This beautiful clay tile is available in grayish smoked, and various glazed colors and will keep its distinctive appearance while withstanding constant exposure to any weather condition.

Traditional designs, as in a Japanese style temple or teahouse, will feature ornaments in various shapes and sizes. The most traditional color used for a Japanese style teahouse or temple is the C09 Japanese Black. This color originated in China and was brought to Japan over 1400 years ago. Japanese Black, called "Ibushi" in Japan, is smoked and is a through body color.

Without the use of decorative ornaments, Oriental-Japanese Style tile is also suitable for western, contemporary designs.

A 50-Year Limited Warranty is available on all M.C.A. tiles.

For more information, please contact MCA sales office at 1-800-736-6221 or sales@mca-tile.com.

CC/CODES, CERTIFICATIONS

- ICC Report ESR-2144
- City of Los Angeles Report RR 24576
- Miami-Dade County, FL NOA No. 07-0905-07 (Expiration Date: 12/20/12)

- Class A, E108 (UL790)
- ASTM C1167, Grade 1

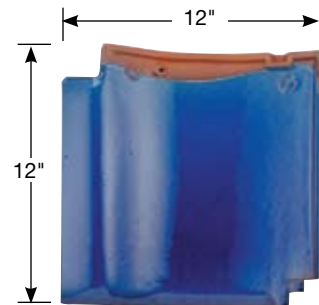

TILE SPECIFICATIONS:

Actual size:	12" x 12"
Exposed size:	10 1/2" x 9 1/2"
Weight per square:	864 lbs
Weight per piece:	6 lbs
No. of pieces per sq:	144 pcs

METRIC TILE SPECIFICATIONS:

Actual size:	305mm x 305mm
Exposed size:	266mm x 241mm
Weight per M2:	54 kg
Weight per piece:	3.6 kg
No. of pieces per square:	15.5 pcs



Field



Eave



*Embossed Eave



Right Gable



Left Gable



*Straight Eave



Right Gable Corner



Left Gable Corner

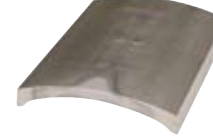

Ridge Field



Ridge End



Ridge Starter



Ridge Down End



Ridge Size 5



Snow Stopper



Standard Ridge Size 6



Sumaru Size 5



Two Forked Ridge



Three Forked Ridge



Three Forked Eave



Three Forked Eave Set



Kaezu Gable Ornament



Kaezu Hip Ornament



Cloud Gable Ornament



Cloud Hip Ornament

*Note: the embossed eave and straight eave are special order items



Japanese Garden, Portland, OR — C09 Japanese Black

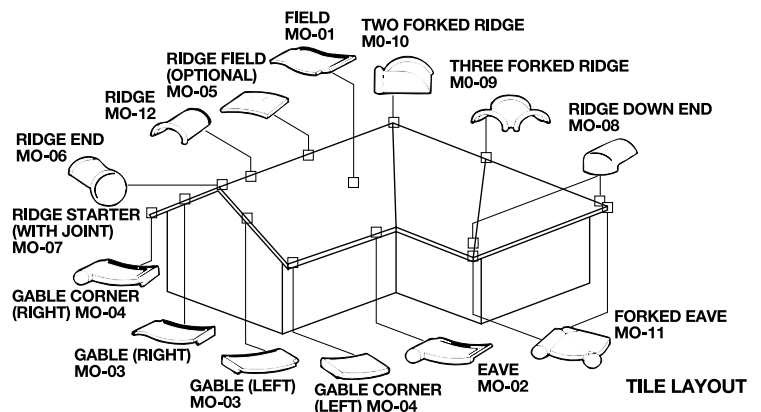



Spaghetti Factory, Portland, OR — Oriental Style, C21 Royal Blue

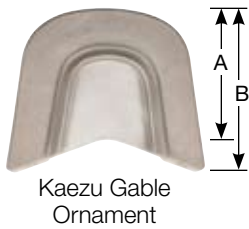

Unit: Inch

Size	A	B	# of Ridge Field
4	5.43	7.16	2 layers
5	6.77	8.19	3 layers
6	7.99	9.72	4 layers
7	9.17	11.5	5 layers

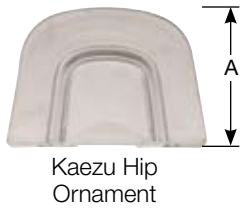

Unit: Inch

Size	A	B	# of Ridge Field
4	5.43	0	2 layers
5	6.77	0	3 layers
6	7.99	0	4 layers
7	9.17	0	5 layers

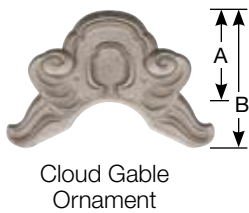

Unit: Inch

Size	A	B	# of Ridge Field
5	6.33	10.3	3 layers
6	7.52	10.9	4 layers
7	8.94	12.5	5 layers



Unit: Inch

Size	A	B	# of Ridge Field
5	6.33	5.12	3 layers
6	7.87	5.31	4 layers
7	8.70	7.40	5 layers

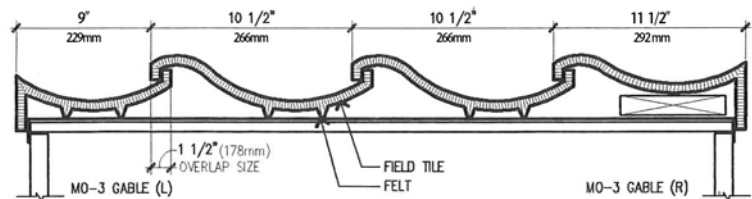
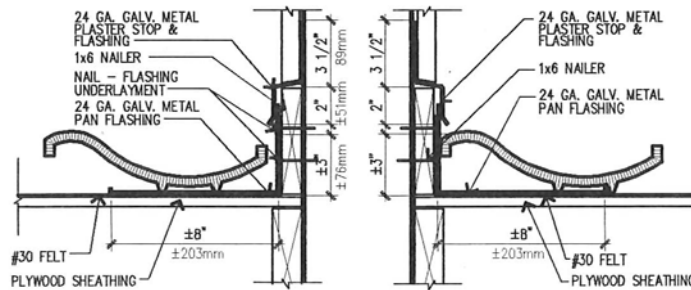
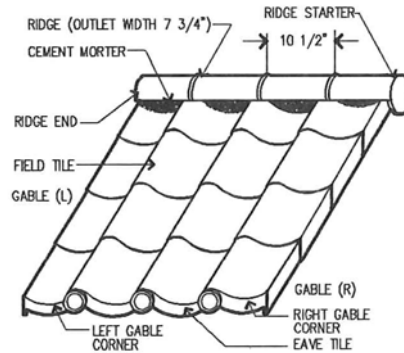
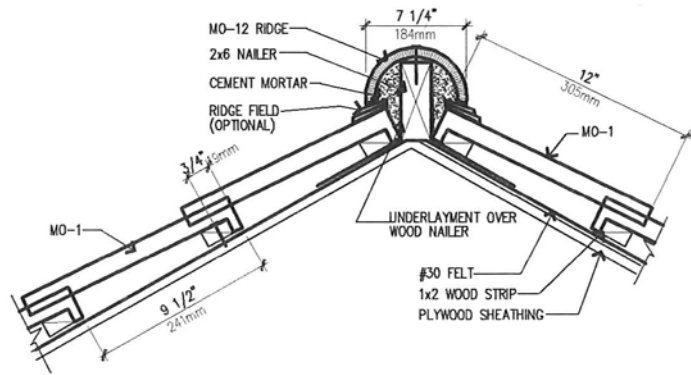
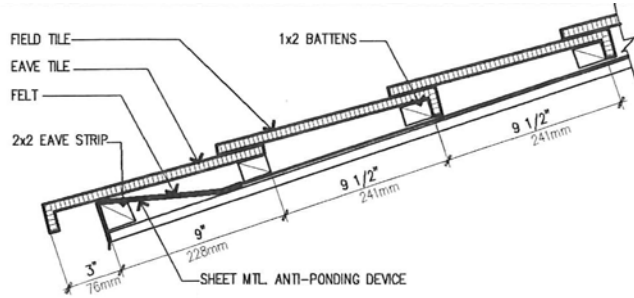

Technical Support

MCA offers free consultations and take offs. Please send us a roofing drawing to scale, or contact our sales office at 1-800-736-7221 or Fax: 951-736-6052 or Email: sales@mca-tile.com



Blue C01



Japanese Black C09



Maroon C07



Dark Green C05



Gray C10



Metallic Silver C23



Maple C12



Chinese Gold C02



Black C03



Matte Brown C14

NOTE: Some tiles may have slight variations in color due to the inherent nature of clay tile and the limitations of the lithographic printing process.



Temecula, California — Metallic Silver C23



Re-Roof Project, Encino, California — Japanese Black C09



Residence, New Mexico — Blue C01

1. GENERAL

(use the standard Part1 of your office)

2. PRODUCTS

2.1. ROOFING TILE:

- A. Where indicated on the Drawings, provide Oriental Style roofing tile manufactured by M.C.A. Clay Roof Tile, Inc., 1985 Sampson Avenue, Corona, CA 92879, phone 800-736-6221, FAX (951) 736-6052, in color " " and with the appropriate number of the following accessory tiles to complete the installation.

1. Field Tiles - MO01;
 2. Eave Tiles - MO02;
 3. Gable Tiles - MO03 (right & left as required)
 4. Gable Corners - MO04 (right & left as required)
 5. Ridge Field - MO05 (optional);
 6. Ridge End - MO06;
 7. Ridge Starter - MO07;
 8. Ridge Down End - MO08;
 9. 3-Forked Ridge - MO09;
 10. Two Forked Ridge - MO10;
 11. Forked Eave - MO11
 12. Ridge - MO12
 13. Gable Ornaments - MO13 (optional);
 14. Other Accessory Tiles (optional)
- B. Comply with pertinent provisions of ASTM C1167 (Grade 1) , and ICC Research Number ESR2144, and with the *Tile Roof Institute Manual*.

2.2. Other materials:

A. Membrane:

1. At roof pitches less than 4:12, except where heavier membrane is required by governmental agencies having jurisdiction, provide not less than two layers of 30 lb (14 kg) asphalt-saturated felt placed at right angles to roof pitch, mopped solidly between layers with 25 lbs (10 kg) of hot asphalt and mopped solidly on top of layers with hot asphalt or code approved alternate.
2. At roof pitches of 4:12 and steeper, provide a minimum of two layers of membrane complying with ASTM D226, Type II, or one layer of membrane complying with ASTM D4869, Type IV or upgrade material placed with minimum 2" (51 mm) headlap and 6" (152 mm) sidelap.
3. Provide in strict accordance with pertinent requirements of governmental and/or other agencies having jurisdiction.

B. Wood Battens and nailers:

1. Eave Strip: Where Oriental Style roofing tile will be installed, provide 2" x 2" (50mm x 50mm) wood batten full length at all eaves to raise the first course of roofing tiles.
2. Battens:
 - a. For roofs with any slope, provide 1" x 2" x 4" (25mm x 50mm x 1.2m) battens, spaced as required, nailed with corrosion resistant 8d nails at 24" (610mm) on centers.
 - b. Space the battens 1" (25mm) apart at ends for drainage, or use battens of any length when elevated above the membrane by 1/4" (6mm) thick spacers.
3. Where indicated on Drawings or otherwise required for proper nailing, provide 2" x 2" (50mm x 50mm), 2" x 3" (50mm x 76mm) and/or 2" x 6" (50mm x 152mm) nailers at ridge, gables and hip.

C. Flashing:

1. Flash at roof valleys in strict accordance with IRC or required by local governmental agencies having jurisdiction:

- a. For valley flashing use not less than 0.019" (G90) (No. 26 gage) (.48 mm thick) corrosion resistant metal, extending at least 11" (279 mm) away from the centerline of the valley each way;
 - b. Provide a splash diverter rib not less than 1" (25 mm) high at the flow line, formed as part of the flashing;
 - c. Provide flashing overlap of not less than 4" (102 mm).
2. For other flashing use not less than 0.019" (G90) (No. 26 gage) (.48 mm thick) corrosion resistant metal; at sides of dormers, chimneys, and other walls, extend flashing at least 6" (152 mm) up the vertical surface.
 - a. Thoroughly counterflash.
 - b. Extend flashing under tile at least 4" (102 mm), and turn the edge up 1-1/2" (38 mm).
 3. At lower side of dormers, chimneys, and other walls, extend flashing at least 3" (76 mm) up the wall and 4" (102 mm) over the tile, and then thoroughly counterflash.
4. At wood saddles and returns, line with not less than 0.019" (G90) (No. 26 gage) (.48mm thick) corrosion resistant metal or 16 oz (454 g) copper extending up sloping roofs not less than 12" (305 mm), and more where necessary, and up vertical walls not less than 6" (152 mm), thoroughly counterflashed.
5. Make all counterflashing plugged, pointed, and secure.
 6. Extend gutter metal up the roof to a point higher than the outer edge of the gutter.

D. Mortar, plastic cement, and sealant:

1. Provide Type M cement mortar complying with ASTM C-270 at all ridges and hips to completely seal the area under the ridge and hip tiles.
2. At gable, hip, ridges, and other conditions, provide a non-running, heavy body, plastic cement composed of asphalt and other mineral ingredients complying with ASTM D4586 and Fed Spec SSC-153 Type 1.
3. When using sealant in lieu of the plastic cement, provide a silicone sealant complying with ASTM D1002 or ASTM E42.

E. Fasteners:

1. Fasteners shall comply with IRC section R905.3.6 and IBC section 1507.3.6 and UBC Section 1507.3.6 Corrosion resistant meeting ASTM A641 Class 1 or approved equal, number 11 gauge diameter and of sufficient length to properly penetrate 3/4" into or through the thickness of the deck or batten, whichever is less. The head of the nail used for tile fastening shall not be less than 5/16 inches and shall comply with ASTM F1667 for dimensional tolerances. Other fastening systems such as screws, wire, or adhesive based systems as approved by code, or local building officials will be allowed.
2. In areas designated by the building official as being subject to high winds that exceed 80 mph, or where roof height exceeds 40 ft (12m) above grade, attach all tiles in strict accordance with Chapter 15 of IBC, Table 15-D-2, Footnote or as required by local governmental agencies having jurisdiction.
 - a. Nail the heads of all tiles;
 - b. Nail rake tiles with two nails;
 - c. Set the noses of all ridge, hip, and rake tiles in a bead of approved mastic.
3. On slopes over 24:12, securely fasten the nose end of all tiles.

3. EXECUTION

3.1 SURFACE CONDITIONS:

- A. Examine the areas and conditions under which work of this Section will be performed. Correct conditions detrimental to timely and proper completion of the work. Do not proceed until unsatisfactory conditions have been corrected.

3.2 INSTALLATION GENERAL:

A. Membrane:

1. Verify that deck surfaces are clean and dry prior to installation of membrane.
2. Remove all foreign particles from substrate to assure proper seating and to prevent water damage.
3. Install the specified membrane in strict accordance with pertinent requirements of governmental agencies having jurisdiction.

B. On vertical applications, and on extremely steep pitches where wind currents may cause lift, set the butt of each tile in a bead of the specified plastic cement or sealant. Use plastic cement and sealant carefully, and avoid smearing the exposed tile surface.

C. Chalk lines:

1. Chalk horizontal and vertical guide lines on the membrane to assure water tightness and proper appearance.
2. Space the chalk lines by measuring the delivered tiles for average length and width exposures.
3. Do not exceed an exposure length 1/8" (3 mm) beyond the average.

3.3 INSTALLING ORIENTAL STYLE ROOFING TILES:

1. Wood Strips:

- a. Install the specified eave strip full length of all eaves.
- b. Install the specified batten strips horizontally at 9" (228mm) centers on the first row and 9 1/2" (242 mm) centers for all rows thereafter.

2. Install the tile in rows from left or right, beginning at the lowest portion of the roof.

- a. Start at the lower left corner with gable corner and eave tile.
- b. Install each tile successively, firmly engaging the tile lugs with the battens, and fastening each tile with one specified fastener.
- c. Length of exposure on field tile shall not exceed 9 1/2" (242 mm) on centers, and width exposure on field tiles shall not exceed 10 1/2" (267 mm) on centers.
- c. Install ridge, hip and other accessory tiles in accordance with pertinent requirements of governmental agencies having jurisdiction.
 - (1) Provide cement mortar Type M complying with ASTM C270 at all ridges and hips to completely seal the area under ridge and hip tiles.
 - (2) Install a thin coat of rich cement mortar (1 part Type I portland cement complying with ASTM C150 to 3 parts sand complying with ASTM C144) along exposed edges of all ridge and hip tiles.
 - (3) Completely and neatly fill and point up all voids.

3. To avoid color patterning, checker boarding, spotting, and stair stepping:

- a. After the installation of each 80 roofing tiles, make a visual inspection from the ground level and at a distance from the building of about 40 feet (12m);
- b. Verify that tile courses follow straight and true lines;
- c. Verify that color range is smooth with no abrupt changes.
- d. Make necessary corrections before proceeding with further installation.

3.4 CLEANING UP:

- A. Upon completion of the work of this Section, and as a condition of its acceptance, completely remove from the job site all tools, equipment, debris, and surplus materials pertaining to this portion of the work.

OM/OPERATION, MAINTENANCE

Over 100 years of product knowledge has enabled us to create a roof tile that is highly resistant to chipping, wearing and fading. We stand behind our product 100%. To install M.C.A. Tile, use adequate numbers of skilled workmen who are thoroughly trained and experienced in the necessary crafts and who are completely familiar with the specified requirements

and the methods needed for proper performance of the work. M.C.A. Clay Roofing Tile may have color variations due to the inherent natural characteristics of the material used. To avoid color patterning, checkerboarding, spotting and stairstepping, the installer should periodically (after installing 80 pieces of roof tile) check the roof color from the ground level at approximately 40 feet (12m) from the building for a color "range." By following

this procedure, patterning or spotting should be avoided by blending the tiles over the entire deck. If this procedure is not followed, M.C.A. can not be held liable or responsible in any way once the tiles have been installed. All claims should be made in writing before installation of the tiles. No claims will be recognized after the tiles have been installed. Once M.C.A. Roof Tiles are installed, no maintenance is required.

